

深圳市宇畅达电子有限公司

承 认 书

SPECIFICATION FOR APPROVAL

客 户 名 称:

Customer Name : _____

客 户 料 号 :

Customer P/N: _____

产 品 名 称:

T-core integrated molding

Product Name: _____

宇 畅 达 料 号:

PIM 201210 系列

YCD P/N: _____

制造厂商	
Manufacturer	
拟 制 Draft	黄小香
审 核 Check	符妃团
日 期 Date	2023-03-18

客户承认印章	
Approval Signet	
日 期 Date	

地址:深圳市光明区玉塘街道光明高新园侨德科技园A座9楼.

Address:9th Floor, Block A, Qiaode Science and Technology Park, Guangming High-tech Park, Yutang Street, Guangming District, Shenzhen

电子邮件 E - mail: wyf_ycd@163.com

● **Features**

- High rated current
- Frequency up to 3 MHz
- 125°C maximum total temperature operation
- Low core loss
- Ultra low buzz noise due to molding construction
- Halogen Free & ROHS compliant

● **Applications**

- Laptops and PCs
- Switch and servers
- Base stations
- DC/DC converters
- Battery powered devices
- SSD modules



● **Product Identification**

YCD **PIM** **201210** **-2R2** **M** **T**
 ① ② ③ ④ ⑤ ⑥

- ① Brand code (品牌代码)
- ② T-core integrated molding (一体成型)
- ③ Specifications and models (规格型号)
- ④ Inductance value (感值)
 R22=0.22UH 3R3=3.3UH 100=10UH 101=100UH
- ⑤ Inductance Tolerance N=±30% M=±20% K=±10%
- ⑥ Packaging (包装) T:编带整盘 B:散装

● **Dimensions (unit:mm)**

Outline Dimensions

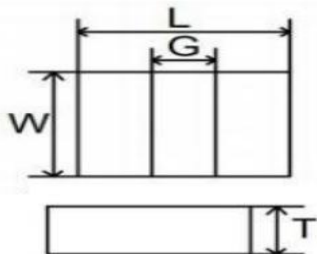

PCB Pattern

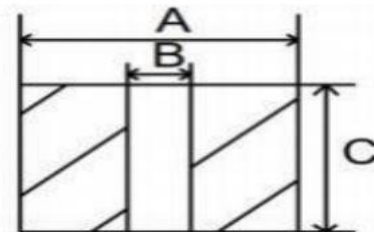

Series	L	G	W	T	A	B	C
201210	2.0±0.2	0.5±0.2	1.2±0.2	1.00Max.	2.10	0.50	1.30

Electrical characteristics

● **PIM201210 TYPE:**

P/N	L0(μH) @ (0A) 1MHz	Rdc(mΩ)		Heat rating current Irms(A)		Saturation current Isat(A)	
		Typical	Max	Typical	Max	Typical	Max
PIM201210-R10MT	0.1	8.0	13	7.5	7.0	8.5	8.0
PIM201210-R22MT	0.22	16	22	7.1	6.5	7.3	6.8
PIM201210-R24MT	0.24	17	23	7.0	6.4	7.2	6.7
PIM201210-R33MT	0.33	24	32	5.5	5.0	6.5	6.0
PIM201210-R47MT	0.47	29	36	4.7	4.3	5.5	5.0
PIM201210-R68MT	0.68	37	43	4.3	4.0	5.0	4.5
PIM201210-1R0MT	1.0	55	63	3.9	3.5	4.0	3.5
PIM201210-1R5MT	1.5	76	85	3.1	2.6	3.2	2.7
PIM201210-2R2MT	2.2	135	150	2.0	1.7	2.7	2.4

• **Notes**

1. All test data is referenced to 25 °C ambient
2. Operating temperature range - 55 °C to + 125 °C
3. Irms (A):DC current (A) that will cause an approximate ΔT of 40 °C(reference ambient temperature is 25 °C)
4. Isat(A):DC current (A) that will cause L0 to drop approximately 30 %
5. The part temperature (ambient + temp rise) should not exceed 125 °C under worst case operating conditions.Circuit design, component placement, PWB trace size and thickness, airflow and other cooling provisions all affect the part temperature. Part temperature should be verified in the end application.
- 6.Absolute maximum voltage 30V

Item	Specification and Requirement	Test Method								
Solderability	1. No case deformation or change in appearance 2. New solder coverage More than 90%	1.Preheat: 155℃±5℃ , 60S±2S 2.Tin: lead-free. 3.Temperature:245℃±5℃, flux 3.0S±0.5S.								
Mechanical shock	1. No case deformation or change in appearance 2. $\Delta L/L_0 \leq \pm 10\%$	1. Acceleration: 100G 2. Pulse time: 6ms 3. 3 times in each positive and negative direction of 3 mutual perpendicular directions								
Mechanical vibration	1. No case deformation or change in appearance 2. $\Delta L/L_0 \leq \pm 10\%$	1. The test samples shall be soldered to the board. Then it shall be submitted to below test conditions. <table border="1" style="margin: 10px auto;"> <tr> <td>Fre. Range</td> <td>10~55Hz</td> </tr> <tr> <td>Total Amplitude</td> <td>1.5mm</td> </tr> <tr> <td>Sweeping Method</td> <td>10Hz to 55Hz to 10Hz</td> </tr> <tr> <td>Time</td> <td>For 2 hours on each X,Y,Z axis.</td> </tr> </table> 2. Recovery: At least 2 hours of recovery under the standard condition after the test, followed by the measurement within 24 ±2 hours.	Fre. Range	10~55Hz	Total Amplitude	1.5mm	Sweeping Method	10Hz to 55Hz to 10Hz	Time	For 2 hours on each X,Y,Z axis.
Fre. Range	10~55Hz									
Total Amplitude	1.5mm									
Sweeping Method	10Hz to 55Hz to 10Hz									
Time	For 2 hours on each X,Y,Z axis.									
Thermal Shock	Inductance change: Within ± 10% Without distinct damage in appearance	1. First -55℃ for 30 minutes, last 125℃ for 30 minutes as 1 cycle. Go through 1000 cycles. 2. Max transfer time is 2 minutes. 3. Measured at room temperature after placing for 24 ±2 hours								
Humidity Resistance	Inductance change: Within ± 10% Without distinct damage in appearance	1.Reflow 2 times, 2.85℃,85%RH,1000 hours 3.Measured at room temperature after placing for 24 ±2 hours								
Low temperature storage	Inductance change: Within ± 10% Without distinct damage in appearance	1. Temperature: -55 ± 2℃ 2. Time: 1000 hours 3. Measured at room temperature after placing for 24 ±2 hours								

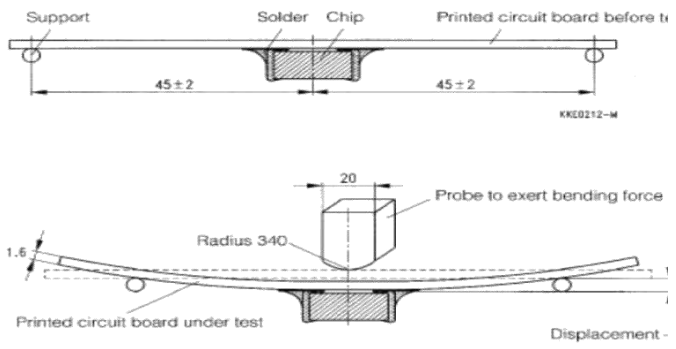
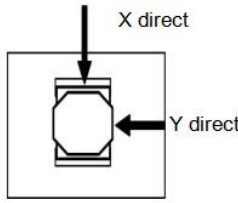
<p>High temperature storage</p>	<p>Inductance change: Within $\pm 10\%$ Without distinct damage in appearance</p>	<p>1. Temperature: $+125 \pm 2^\circ\text{C}$ 2. Time: 1000 hours 3. Measured at room temperature after placing for 24 ± 2 hours</p>
<p>Board Flex</p>	<p>Inductance change: Within $\pm 10\%$ Without distinct damage in appearance</p>	<p>1、 Run through IR reflow for 2 times; 2、 Place the 100mm X 40mm board into a fixture similar to the one shown in below Figure with the component facing down 3 、 The apparatus shall consist of mechanical means to apply a force which will bend the board (D) x = 2 mm minimum. 4、 The duration of the applied forces shall be 60 ± 5 sec. The force is to be applied only once to the board.</p> 
<p>Terminal Strength</p>	<p>No removal or split of the termination or other defects shall occur.</p>	<p>1、 The test samples shall be soldered to the board 2、 Push the product vertically from the side of the sample using the thrust tester. 3、Automotive electronics: 17.7N, 60S\pm1s, X , Ydirect.</p> 

Recommended Soldering Technologies

1、 Re-flowing Profile

Preheat condition: 150 ~200°C/60~180sec.
 Allowed time above 217°C: 80~120sec.
 Max temp: 260°C
 Max time at max temp: 10 sec.
 Solder paste: Sn/3.0Ag/0.5Cu
 Allowed Reflow time: 2x max

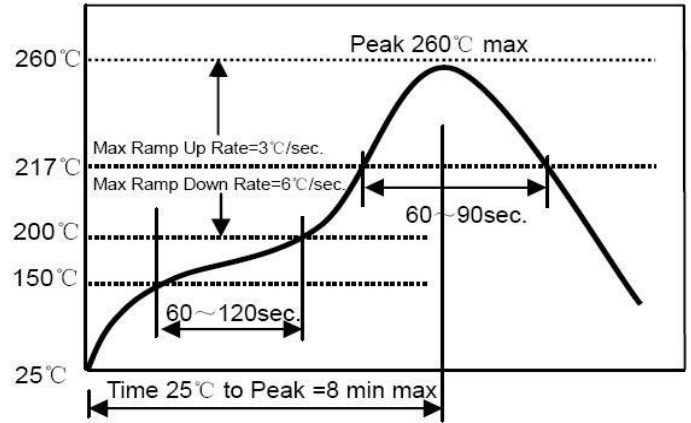

2、 Iron Soldering Profile

Iron soldering power: Max. 30W
 Pre-heating: 150°C/60sec.
 Soldering time: 3sec. Max.
 Solder paste: Sn/3.0Ag/0.5Cu
 Max.1 times for iron soldering

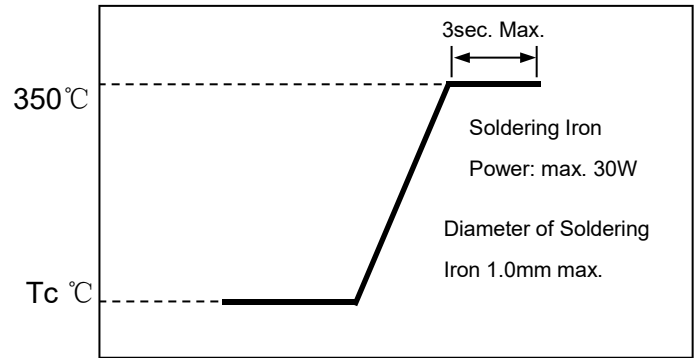

Packaging, Storage and Transportation

Tape Carrier Packaging:

Type	Standard Quantity (pcs/reel)
201210	3000

●Dimension of plastic taping: (Unit: mm)

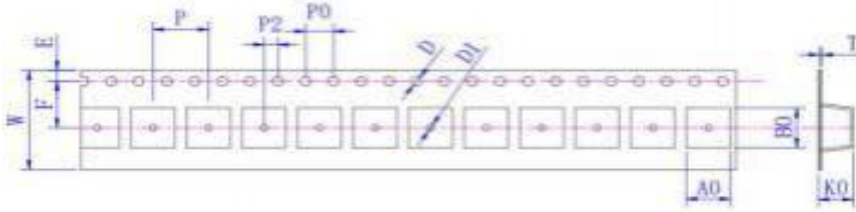

Series	W ±0.30	A0 ±0.05	B0 +0.1/-0	D +0.1/-0	D1 Min	E ±0.10	F ±0.10	K0 ±0.05	P0 ±0.10	P2 ±0.10	P ±0.10	T ±0.05
201210	8.00	1.50	2.30	1.50	1.0	1.75	3.50	1.20	4.00	2.00	4.00	0.23

●Peel force of top cover tape

The peel speed shall be about 300mm/minute

The peel force of top cover tape shall be between 0.1 to 1.3 N

Label

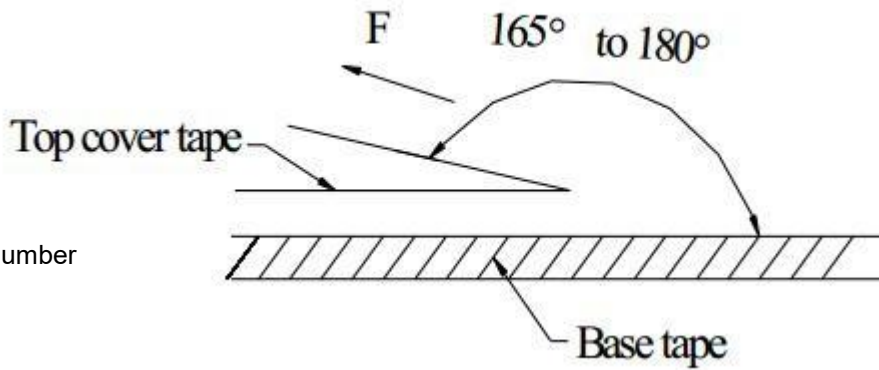

- Label on the reel
- Customer's part Number
- Lot Number
- Quantity
- date code

- Shipping Label
- Customer's part Number
- Manufacturer's part Number
- Quantity
- date code

