

深圳市宇畅达电子有限公司

承 认 书

SPECIFICATION FOR APPROVAL

客户名称:

Customer Name : _____

客户料号:

Customer P/N: _____

产品名称:

功率电感

Product Name: _____

宇畅达料号:

SNR3015TYD-系列

Yuchangda P/N: _____

制造厂商 Manufacturer	
拟制 Draft	黄小香
审核 Check	符妃团
日期 Date	2022-08-11

客户承认印章 Approval Signet	
日期 Date	

地址: 深圳市光明区玉塘街道光明高新园侨德科技园A座9楼.

Address: 9th Floor, Block A, Qi aode Science and Technology Park, Guangming High-tech Park, Yutang Street, Guangming District, Shenzhen

电子邮件E mail: wyf_ycd@163.com

文件编号 File Number	YCD-WI-3624	版本号 Version Number	A	页码 page	1/3
---------------------	-------------	-----------------------	---	------------	-----

1、外形尺寸 Dimension :

单位Unit: mm

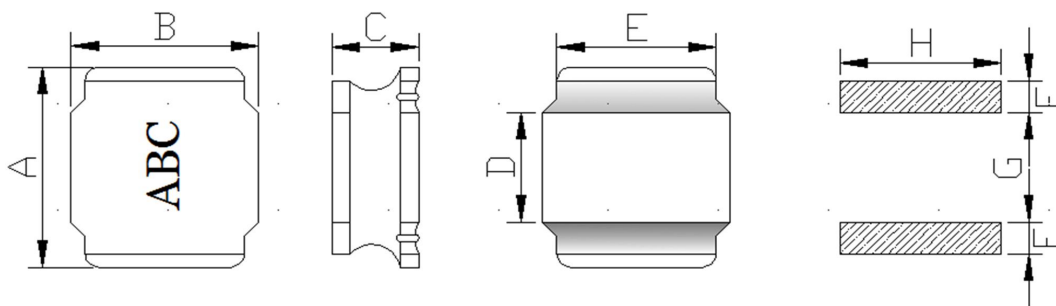

A	3.00±0.2
B	3.00±0.2
C	1.5 Max
D	1.5±0.2
E	2.5Ref
F	0.8Ref
G	1.5Ref
H	2.7Ref

2、产品品名构成 Product Spec. Model

SNR 3015T Y D - 2R2 N

a b c d e f

a: 系列名称 Series name

b: 产品尺寸 Product dimensions (A x B x C)

c: 密封方式 Sealing way (L: 冷封 Cold seal Y: 热封 Heat seal)

d: 印字方向 Lettering direction ▶

e: 电感值 Inductance Value

(1R0:1.0uH; 100: 10uH; 101:100uH)

f: 电感公差 Inductance Tolerance (K:10% ; M:20% ; N:30%)

▶ Lettering direction

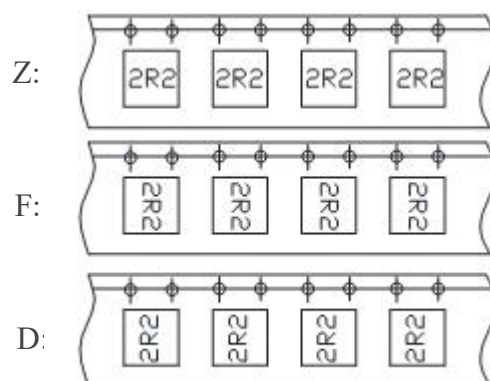

3、结构 Structure

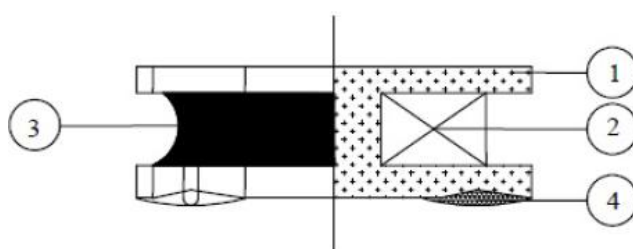

4、材料清单 MATERIAL LIST

NO.	PARTS	MATERIAL	UL FILE NO.	TEMP. CLASS
1	DRUM CORE	Ni-Zn CORE OR EQUIVALENT	NA	NA
2	WIRE	POLYURETHANE ENAMELLED COPPER WIRE OR EQUIVALENT	E258243	180°C
3	ADHESIVE	EPOXY RESIN OR EQUIVALENT	NA	NA
4	SOLDER	Sn99.3-Cu0.7 OR EQUIVALENT	NA	NA

*NA:NOT APPLICABLE.

6、产品包装 Packaging

1) 载带包装示意图 Tape packing diagram

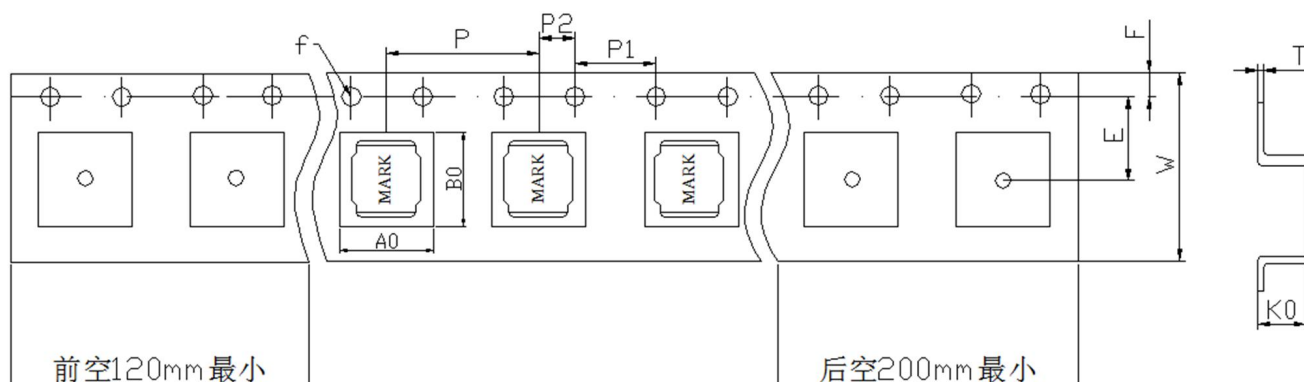

ITEM	W	A0	B0	K0	P	E	F	D0	P0	P2	T
DIM	8.00	3.20	3.20	1.80	4.00	3.50	1.75	1.50	4.00	2.00	0.30
TOLE	±0.3	±0.1	±0.1	±0.1	±0.1	±0.1	±0.1	+0.1	±0.1	±0.1	±0.05

2) 卷盘包装示意图 Tape packing diagram

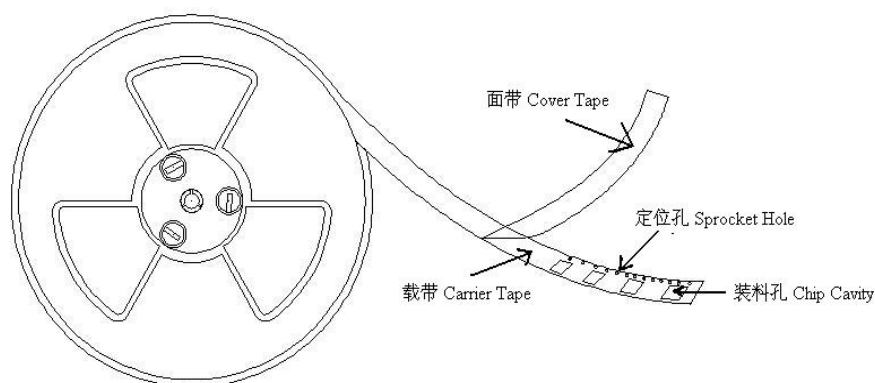

3) 剥离强度要求 Peeling required

- ① F 力大小: 20~100g;
- ② 面带剥离角度: 165°~180°。

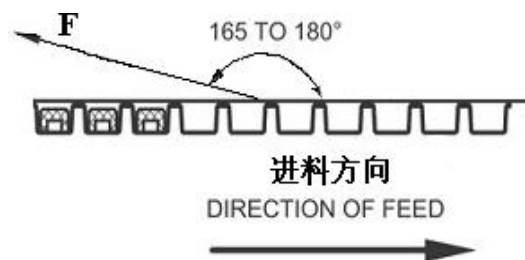

4) 包装数量 Packing quantity

项目	数量 (PCS)	尺寸规格 (mm)
盘	2000	7"
内盒	20K	185mm*185mm*120mm
外箱	120K	395mm*385mm*205mm